

Powerline

Single Power Connectors



Ten 47 Limited

Unit 2B Frances Industrial Park
Kirkcaldy, Scotland, UK
KY1 2XZ

Tel: +44 (0)1592 655725

Fax: +44 (0)1592 651049

Email: sales@ten47.com

www.ten47.com

Introduction

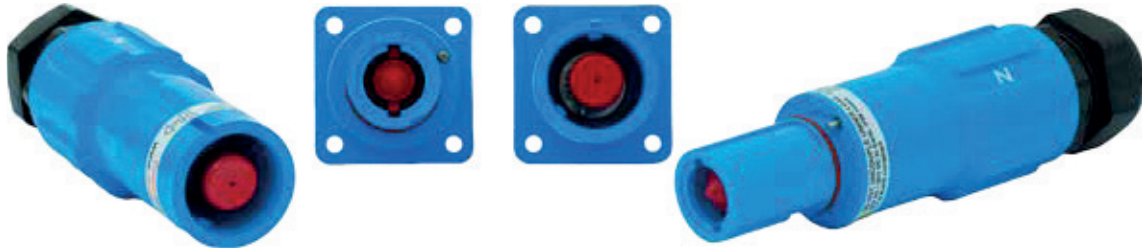

Background

Keyed "L" slot single pole connectors have become widely adopted in a diverse range of applications and industries.

One of the main features of early designs was the mechanically keying of the connectors to prevent possible connection errors; i.e., a Phase Line cannot be connected into Earth Line, etc.

It was evident that several enhancements to existing designs were possible to further improve the product but at the same time remaining intermateable.

Typical Applications

- Power Distribution
- Utilities
- Electric Vehicles
- Railway Equipment
- Military Field Power
- Mobile Generators
- Loadbanks
- Back-up Power Systems

Powerline Features

- 500 Mating Cycles minimum
- Intermateable with other versions
- IP2X Finger Protected contacts
- IP68 sealed when mated
- Remote tool required to release mated connectors
- For use with Electrical Power Cables
- Heavy Duty Hand Grips
- Clip retained contacts
- No Dowel/Cotter pin required
- Cable sizes from 25mm² to 300mm²
- Facilitate cables up to 37mm Ø
- High Impact Insulators
- Harmonised Colour Coding
- CE Compliant
- EN/ESI compliant Creepage and Clearance distances
- Multi-louver contact system
- Mechanically keyed to prevent connection errors
- Permanent Marking
- Set Screw and Crimp contact versions
- UL94 VO Flame Retardant
- Field Assembly and Repair
- No special tools required
- Daisy Chain hook up system

Clip Contact Retention System

- Some versions of this connector format have relied upon the Electrical Contact being retained within the Insulator by means of a plastic cotter/dowel pin.
- These pins are forced through a mating hole in the Insulator and contact and any re-use of the same pin may adversely affect the IP sealing of the connectors.
- Ten 47 "Powerline" contacts are retained by means of a spring clip design that can retain the equivalent weight of 100 metres of 240mm² cable.
- The contacts are inserted from the rear and "snap" into position within the Insulator with no requirement for any cotter/dowel pin or assembly tools.
- As our clip design does not require any holes through the Insulator, it provides several advantages over the "cotter/dowel pin" design;
 - On-Centre contact alignment ensures low connector mating forces.
 - Improved mechanical Insulator strength and Environmental Sealing to IP68.
 - Improved electrical integrity of the Insulator.
 - Reduced assembly times.
 - The contacts can be removed and replaced with no detrimental affect to the Insulator.
 - No replacement parts (cotter/dowel pins) are required.
- Contacts for 35mm² to 150mm² cable are supplied with a sliding collar which can be removed as shown below.

Step 1



Step 2

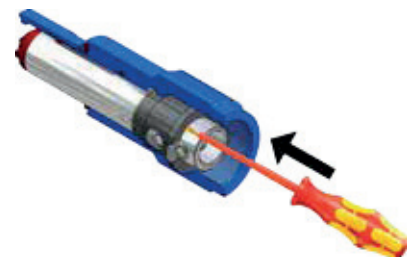

Step 3



Step 4

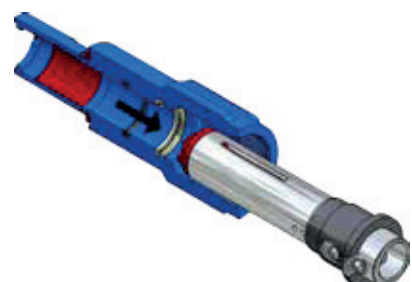

Clip Contact Retention System

Contacts for 185mm² to 300mm² cable can be removed with a simple tool as shown below.

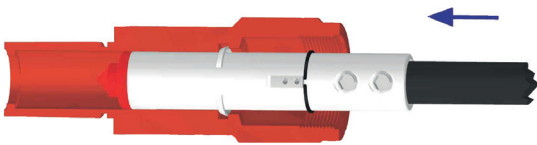

Position the contact keyway and insert into the rear of Insulator.

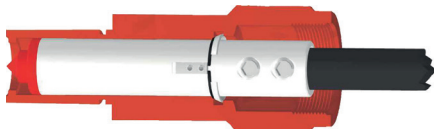

Push the cable/contact until the clips "snap" into position. You will feel and hear the locking during this operation.



To remove, place the removal tool around the cable and position into the rear of the Insulator.



Push the contact from the front and it will release from the Insulator.

Part Number Configuration

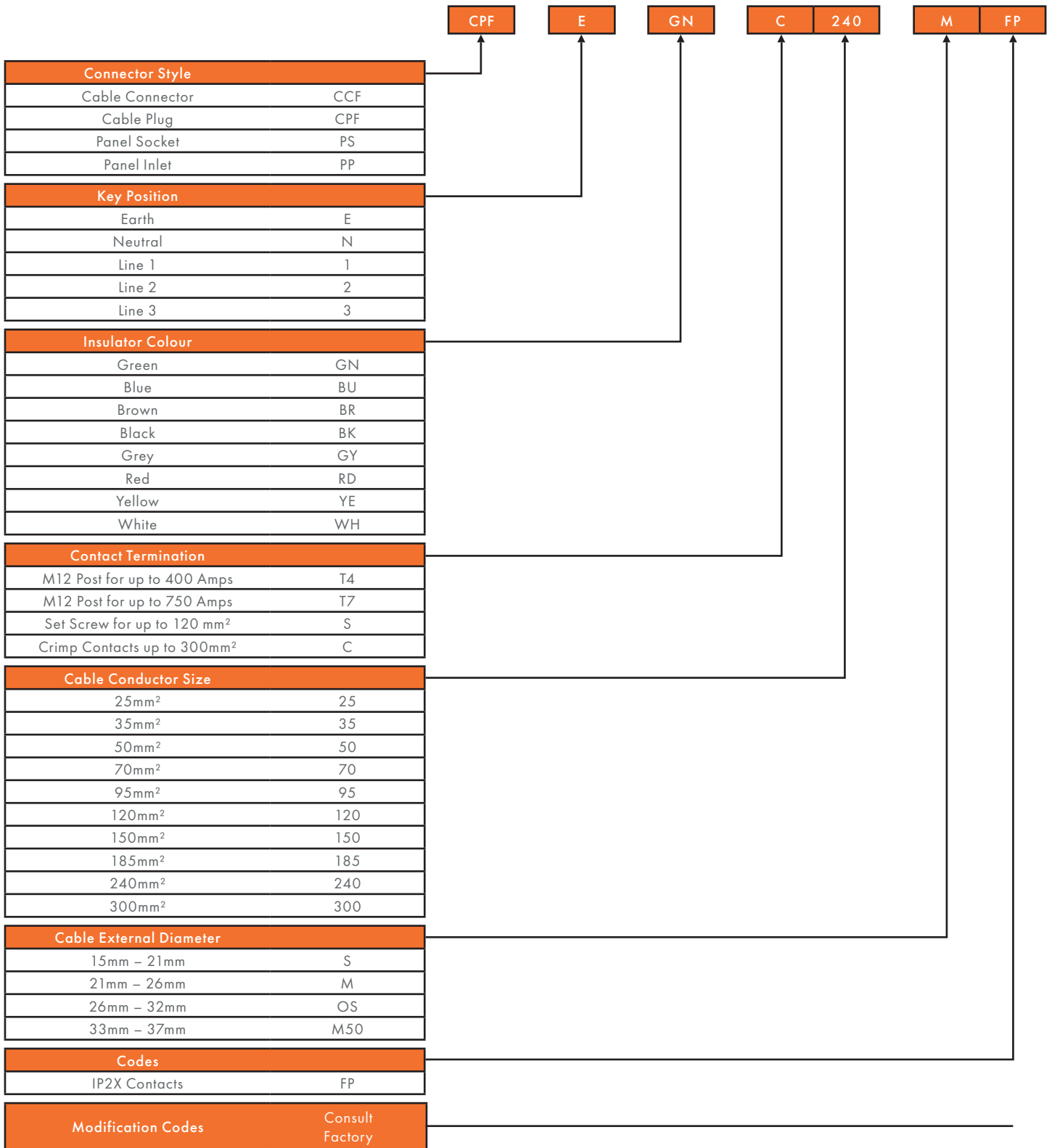

	Earth	Neutral	Line 1	Line 2	Line 3
UK & Europe	Green	Blue	Brown	Black	Grey
UK (Old)	Green	Black	Red	Yellow	Blue
USA	Green	White	Black	Red	Blue
Australia	Green	Black	Red	White	Blue

Powerline Cable Connectors

Cable Connector (Line Source)

Style "CCF"

Cable Connectors are typically used as the Live or Supply side of the circuit and utilise a Solid Insulated contact tip to provide IP2X Finger Protection when unmated. "CCF" Connectors incorporate a slot that engages with the Locking Pin on both the mating Panel Inlet and Cable Plug connectors.



Cable Plug (Line Drain)

Style "CPF"

"CPF" Connectors utilise a spring-mounted contact with a Double Insulated Sleeve that provides IP2X Finger Protection when unmated. The "CCF" contact depresses the spring and sleeves to obtain Electrical connection. When unmated, they return automatically to the IP2X position. A Locking Pin engages with the slot on both the Panel Socket and Cable Connectors when mated.



- When disconnected all connectors are IP2X Protected.
- In Line Connectors are supplied as standard with Metric Cable Glands.
- Connectors seal to IP68 when mated.
- Once mated, the connectors are separated by using a remote unlocking key.
- Panel connectors can be Front or Rear mounted on equipment.
- All connectors are mechanically keyed and individually colour coded to help prevent any possible cross connection errors. (See page 6 for key positions and colours).
- Plastic Push/Pull or Environmental Locking caps are available for all connectors.

Powerline Panel Connectors

Panel Socket (Panel Source)

Style "PS"

Panel Socket Connectors are typically used as the Live or Supply side of the circuit and utilise a Solid Insulated contact tip to provide IP2X Finger Protection when unmated. "PS" Connectors incorporate a slot that engages with the Locking Pin on both the mating Panel Plug and Cable Plug connectors.

Previous version "PSF" is available on request.

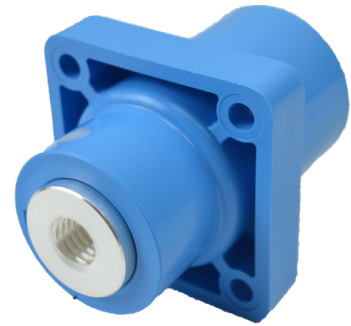
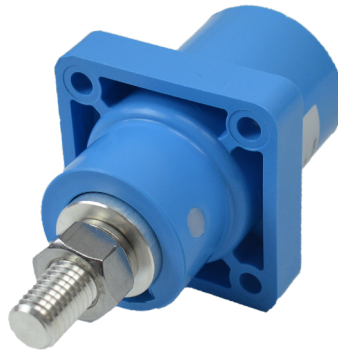

M12 Threaded Post

Female Thread version

Panel Plug (Panel Drain)

Style "PP"

"PP" Connectors utilise a spring-mounted contact with a Double Insulated Sleeve that provides IP2X Finger Protection when unmated. The "CS" contact depresses the spring and sleeves to obtain Electrical connection. When unmated, they return automatically to the IP2X position. A Locking Pin engages with the slot on both the Panel Socket and Cable Socket when mated.

Previous version "PIF" is available on request.

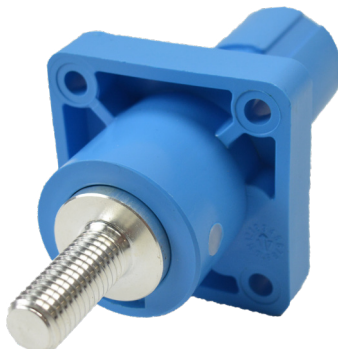

M12 Threaded Post

Female Thread version

Environmental Locking Caps

Environmental caps offer increased protection.

Environmental caps are manufactured in high impact Black Acetal with retention line of 1.5mm thick nylon thread crimped with tinplated copper ferrules. In addition to the features of the standard dust cap, they offer IP67 rated sealing and made to fit into keyway to turn and hold in place.



ENV-CAP-PS

ENV-CAP-PP



ENV-CAP-CS

ENV-CAP-CP

Standard Dust Caps

CAP-CS CAP-CP CAP-PS CAP-PP



Plastic Push/Pull caps are fitted with retention line of 1.5mm thick nylon thread crimped with tinplated copper ferrules.

Ideal for indoor or waterproofed cabinets to protect against dust/particle ingress.

Powerline Single Bimetallic Pole Connector For Aluminium Cable

Part Number Configuration



Example CPFA E GN C 240 M50 FP

Connector Style	
Cable Connector	CCFA
Cable Plug	CPFA

Key Position	
Earth	E
Neutral	N
Line 1	L1
Line 2	L2
Line 3	L3

Insulator Colour	
Green	GN
Blue	BU
Brown	BR
Black	BK
Grey	GY
Red	RD
Yellow	YE
White	WH

Contact Termination	
Crimp Contacts	C

Cable Conductor Size	
120mm ²	120
240mm ²	240
Other sizes are available on request	

Cable External Diameter	
26mm – 33mm	OS
33mm – 37mm	MSO

Codes	
IP2X Contacts	FP

Conductor Size	Male Contact Part No.	Female Contact Part No.
185mm ²	PCBM185M	PCBM185F
240mm ²	PCBM240M	PCBM240F
300mm ²	PCBM300M	PCBM300F

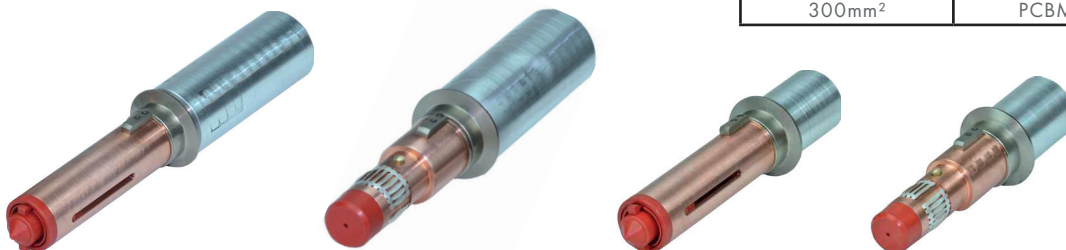

Cable Splitters

Incorporating our Powerline Panel connectors and housed in a tough Rubber enclosure, these units can be configured for several inlet/outlet options utilising either our T4 or T7 Panel connectors.

All Cable and Panel connectors are IP2X rated, once assembled and coupled, the Cable Splitter is sealed to IP65.



CST1PS2PS-N-T7

T-Piece Description	Inlet A	Inlet B	Inlet C	Part Number
1 Inlet, 2 Outlet	1 x PS	1 x PS	1 x PS	CST1PS2PS-*-*
	1 x PS	1 x PI	1 x PI	CS1PS2PI-*-*

- Please add E (Earth), N (Neutral), 1 (Line 1), 2 (Line 2) or 3 (Line 3) as required.
- Other Inlet/Outlet configurations are possible. Please consult our factory to discuss any requirements.

Connector Dimensions

Cable Plug

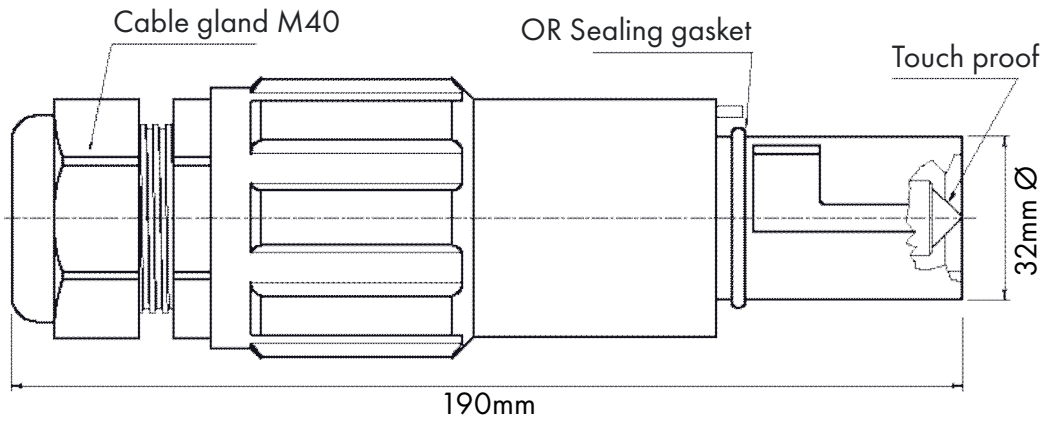

Cable Connector

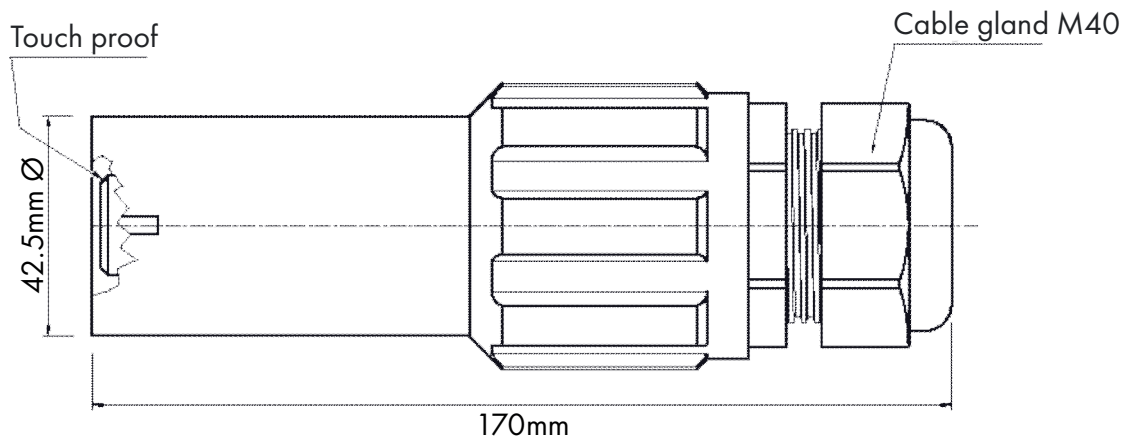

Panel Connectors Dimensions

Panel Socket – M12 Threaded Post

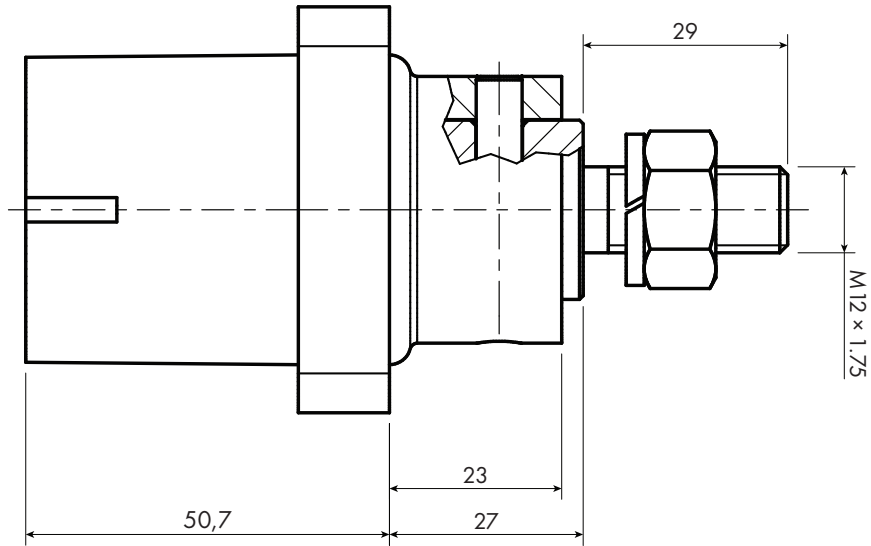

Panel Socket – Female Thread version

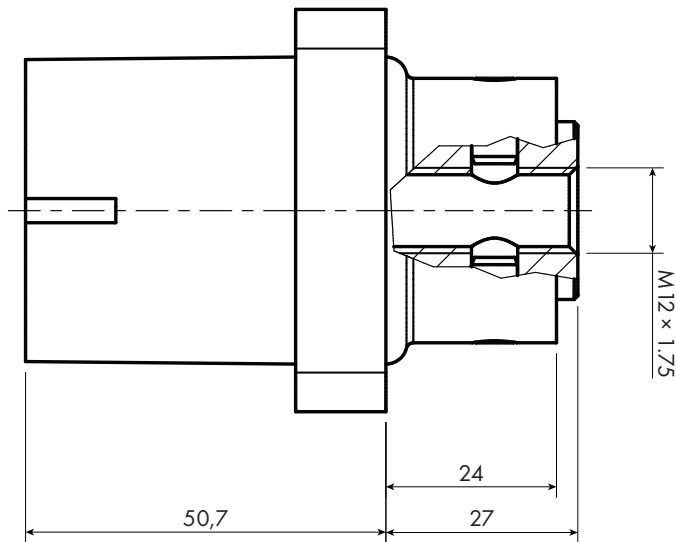

Cut Out Dimensions

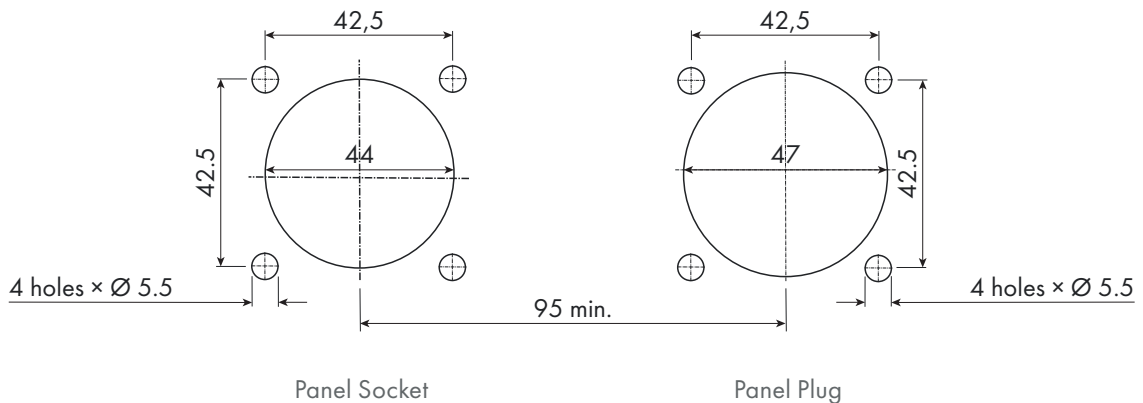

Panel Connectors Dimensions

Panel Plug – M12 Threaded Post

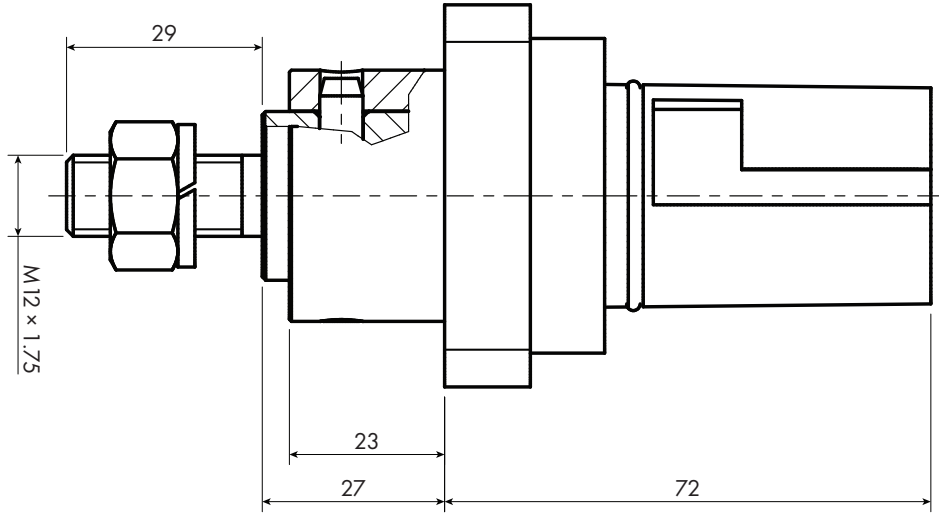

Panel Plug – Female Thread version

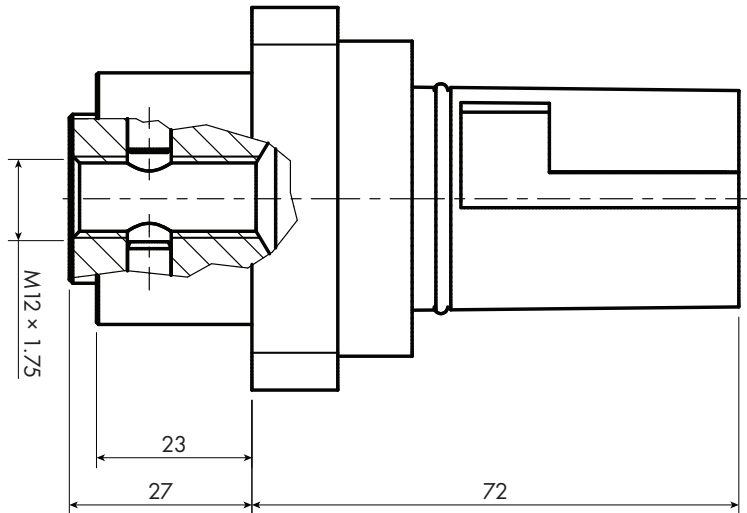

Cut Out Dimensions

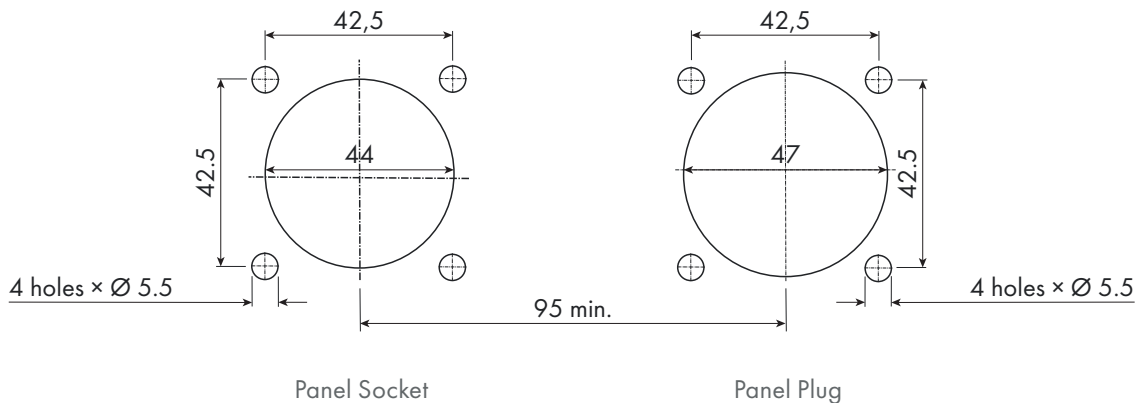

Definitions and Terminology

Rated Current

The current rating of the connector is determined by the conductor size and type utilised. Values are taken from IEE wiring regulations BS7671 Table 4F1A Reference method 12 (cables in Free Air). The quoted values relate to non-armoured Single core, copper stranded cable with Rubber insulation and an operating temperature of 85°C. The de-rated values for ambient temperature are taken from Table 4H2A.

Rated Voltage

The determined voltage of a connector from which the related operating characteristics are defined.

Contact Resistance

The resistance occurring at the point of two contact areas. Its value is calculated with the measured voltage drop and the rated current.

Test Voltage

The voltage the connector will withstand without breakdown or flashover under test conditions.

Surge Current

The current the connector will withstand during a short time surge or current spike. Duration 10msecs.

Ingress Protection

Level of resistance to dust and water ingress according to EN60529. When mated, Powerline connectors meet the requirements of IP68, submersible in water and closed to entry of foreign objects.

Creepage

The shortest distance along the surface of the Insulating material between two conductive parts. This is also a function of the properties of the insulating material.

Clearance

The shortest distance in air for arcing potential between two conductive parts.

CE Cable Glands

In December 1999, European standard EN50262 (metric glands) replaced the withdrawn standard DIN46320 (PG glands). The transition period for granting certification marks for PG glands ended on 1st March 2001. In order to comply with CE Certification requirements, Powerline utilises metric glands compliant with current legislation and specifications.

Mating Cycles

The minimum number of continuous mating operations the connectors will withstand without damage to their operation or safety. The values assume normal usage.

Set Screw Termination

Two threaded set screws at the cable entry point into the contact. The screws are tightened to compress a copper sleeve(s) fitted around the strands of the cable conductor. The standard contact is supplied with a sleeve suitable for 120/150mm² CSA. When used with smaller cable sizes, additional sleeves are required to suit the cable size. The contacts are Silver Plated Copper Alloy.

Crimp Termination

Compression termination. The contacts are Silver Plated Oxygen Free high conductivity Copper.

Fixed Locking

Once mated, the connectors are locked together via a metal pin. Connectors can be unlocked via the integrated locking release key. This version provides additional safety where unsupervised or public access to live equipment may be possible.

Harmonised Colour Coding

On 31st March 2004, the IEE published Amendment No. 2 to BS7671: 2001 (IEE Wiring Regulations). This amendment specifies new cable core colours for Electrical installations in the UK. These "Harmonised" colours bring the UK more closely in line with practice in mainland Europe. Electrical installation work commencing after 31st March 2004 may use harmonised colours or the pre-existing colours, but not both. Work commencing after 31st March 2006 will be required to comply with harmonised colours and must not use old colours.

Powerline Series

New Harmonised Colour Codes and Marking for Single and Three-Phase applications.

Slide Locking

A version is available for the cable plug where a slide pin is used to allow unlocking without a remote key.

Function	Alphanumeric	Colour
Phase of single phase circuit	L	Brown
Neutral of single or three-phase circuit	N	Blue
Phase 1 of three-phase a.c. circuit	1	Brown
Phase 2 of three-phase a.c. circuit	2	Black
Phase 3 of three-phase a.c. circuit	3	Grey

Connector Parameters

Technical Parameter	Value
CCF-*-*-S120-S-FP weight	0.53kg
CCF-*-*-S120-M-FP weight	0.51kg
CCF-*-*-S120-OS-FP weight	0.54kg
CPF-*-*-S120-S-FP weight	0.50kg
CPF-*-*-S120-M-FP weight	0.48kg
CPF-*-*-S120-OS-FP weight	0.51kg
CCF-*-*-C240-OS-FP weight	0.63kg
CPF-*-*-C240-OS-FP weight	0.60kg
PSF-*-*-T4-FP weight	0.37kg
PIF-*-*-T4-FP weight	0.34kg
PSF-*-*-T7-FP weight	0.39kg
PIF-*-*-T7-FP weight	0.35kg
Set Screw Control Tightening Torque	12Nm
Panel Contact Tightening Torque	30Nm max
Cable Gland Tightening Torque	13Nm
Minimum Mating Cycles	500
Contact Retention in Insulator	2.5kN Axial Load
Flammability	UL94 V0
Environmental Sealing (when mated)	IP68
Rated Voltage to Earth	2000V AC
Minimum Flashover (EN60309-1)	6.8kV AC – 1 minute
Minimum Insulation Resistance	5Gohms @ 500v
Operating Voltage	1000V AC or DC
Test Voltage (Mated Condition)	5kV – 1 minute @ 50Hz
Contact Resistance	<5mohms
Short Circuit Current – 1 second	16kA
Short Circuit Current – 3 seconds	12kA
Surge Current (DIN VDE 0102/1.90)	62kA – 10mseconds
Creepage Distance	>25mm
Clearance Distance	>25mm
Temperature Range	-30°C / +125°C

Connector Rated Current

Connector Style	Part Number	Current (Amps)	Minimum Cable c.s.a. for Rated Current (in free air)	Contact Termination
Panel Socket	PSF-*-**_T4	431	120mm ²	M12 Thread
Panel Inlet	PIF-*-**_T4	431	120mm ²	M12 Thread
Panel Socket	PSF-*-**_T7	750	300mm ²	M12 Thread
Panel Inlet	PIF-*-**_T7	750	300mm ²	M12 Thread
Cable Connector	CCF-*-**_S25-S	154	25mm ²	Set Screw
Cable Connector	CCF-*-**_S35-S	192	35mm ²	Set Screw
Cable Connector	CCF-*-**_S50-S	235	50mm ²	Set Screw
Cable Connector	CCF-*-**_S70-S	303	70mm ²	Set Screw
Cable Connector	CCF-*-**_S95-S	370	95mm ²	Set Screw
Cable Connector	CCF-*-**_S120-S	431	120mm ²	Set Screw
Cable Plug	CPF-*-**_S25-S	154	25mm ²	Set Screw
Cable Plug	CPF-*-**_S35-S	192	35mm ²	Set Screw
Cable Plug	CPF-*-**_S50-S	235	50mm ²	Set Screw
Cable Plug	CPF-*-**_S70-S	303	70mm ²	Set Screw
Cable Plug	CPF-*-**_S95-S	370	95mm ²	Set Screw
Cable Plug	CPF-*-**_S120-S	431	120mm ²	Set Screw
Cable Connector	CCF-*-**_C185-M	573	185mm ²	Crimp
Cable Connector	CCF-*-**_C240-OS	679	240mm ²	Crimp
Cable Connector	CCF-*-**_C300-M50	750	300mm ²	Crimp
Cable Plug	CPF-*-**_C185-M	573	185mm ²	Crimp
Cable Plug	CPF-*-**_C240-OS	679	240mm ²	Crimp
Cable Plug	CPF-*-**_C300-M50	750	300mm ²	Crimp

* = Key Position (Earth, Neutral, Line 1, Line 2, Line 3)

** = Colour (Green, Blue, Brown, Black, Grey)

Reference Data for Cable Selection

The Current Rating of the connector is determined by the conductor size and type utilised. For this publication, values are taken from IEE wiring regulations BS7671 Table 4F1A Reference Method 12 (Free Air). The quoted values relate to non-armoured Single Core, Copper stranded cables with Rubber Insulation and an operating temperature of 85°C.

Derating Data for 85°C for Rubber Insulated Cables

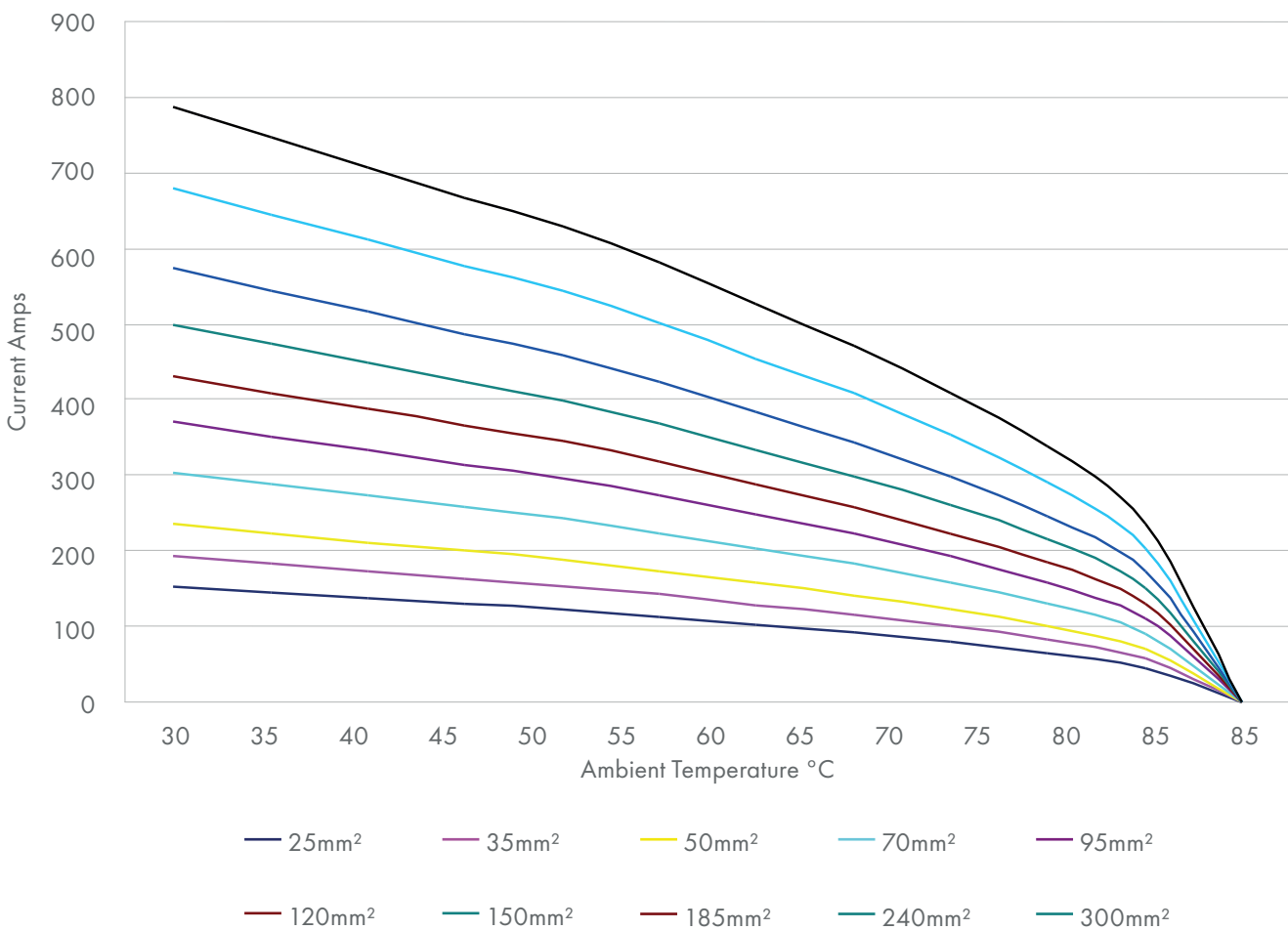

Powerline contacts are suitable for termination onto Aluminium conductors for short term applications. However, we recommend that bi-metallic contacts or cable lugs are used to provide optimum electrical and mechanical performance over time and repeated use.

Tools and Data

Cable Size	Up to 120mm ²	185mm ² Class 2	240mm ² Class 2	300mm ² Class 2	185mm ² Class 5	240mm ² Class 5	300mm ² Class 5
Insulation Strip (dim C)	33mm	40mm	40mm	40mm	40mm	40mm	40mm
Recommended Number of Crimps	N/A (set screw)	2	3	3	2	3	3
Hand Operated Crimp Tool	N/A	HT131-C	HT131-C	HT131-C	HT131-C	HT131-C	HT131-C
Cordless Hydraulic Crimp Tool	N/A	B131-C	B131-C	B131-C	B131-C	B131-C	B131-C
Crimp Die Set	N/A	ME4D-C	ME60-C	ME60-C	T185-CF	T240-CF	T300-CF
Contact Removal Tool	REM-185P	REM-240P	REM-240P	REM-300M50P	REM-240P	REM-240P	REM-300M50P

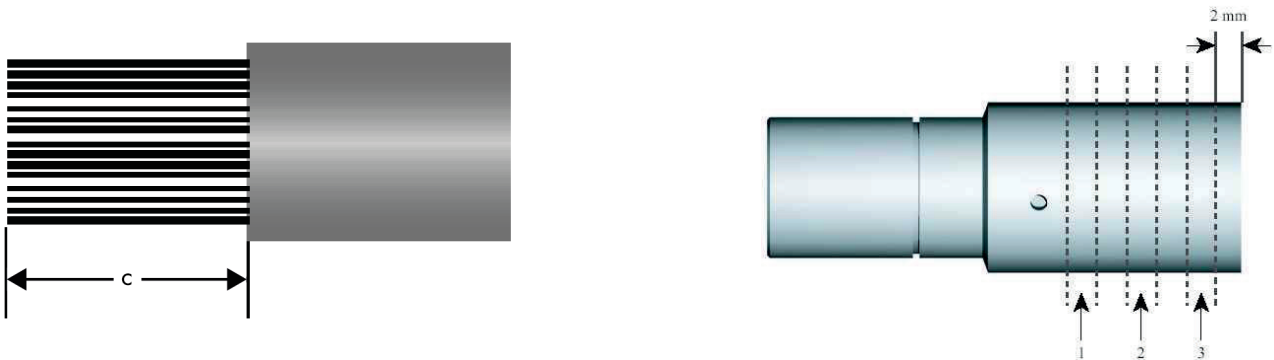

- It is recommended to apply multiple crimp compressions in accordance with the above table to obtain optimum mechanical and electrical performance.
- The correct sequence of compressions is as shown above.
- When correctly terminated, the Electrical and Mechanical performance of the Crimp will be in accordance with IEC61238-1.
- 185mm² Crimp: Tensile Strength = 11,100N min.
- 240mm² Crimp: Tensile Strength = 14,400N min.
- 300mm² Crimp: Tensile Strength = 18,000N min.
- Due to the numerous cable types available, it is recommended to contact Ten 47 to confirm cable and crimp suitability.

Connector Release Key: REM-FL



To release a mated pair of connectors without the integrated locking key, we recommend the use of our REM-FL key. It is designed to push the secondary locking pin away from the locked position without any damage occurring to the Insulator.

Crimping Tools



Crimping Tool HT131-C

This tool features a double speed action; a fast advancing speed for rapid approach of the dies to the contact and a slower, more powerful speed for crimping.

The tool will accept all semi-circular slotted dies common to most 130kN tools.

The built in safety valve will bypass the oil supply when maximum pressure is reached.

A pressure release system can easily be operated at any stage of the compression.



Crimping Tool B131-C

14.4v cordless hydraulic crimping tool, lightweight and balanced for single hand operation.

This tool features a double speed action; a fast advancing speed for rapid approach of the dies to the contact and a slower, more powerful speed for crimping.

The tool will accept all semi-circular slotted dies common to most 130kN tools.

For ease of operation and operator comfort, the tool head can be fully rotated through 180°.

A microprocessor controls the tool operation and automatically cuts out the motor on completion of the crimping operation. This saves energy and extends the battery life.

The residual battery capacity is automatically displayed after every cycle.

Fitted with an integral socket for connection to a 12v DC external power supply.



ISO 9001 : 2008
Certificate : F5581148

Also available from Ten 47



High Quality, Durable
Cable Protection Systems

www.cableguard.eu



 **RENNSTEIG**

Cable and Connector tooling

www.ten47.com/products/temporary-power/rennsteig-tools



Ten 47 Limited

Unit 2B Frances Industrial Park
Kirkcaldy, Scotland, UK
KY1 2XZ

Tel: +44 (0)1592 655725

Fax: +44 (0)1592 651049

Email: sales@ten47.com

www.ten47.com