

USER MANUAL

PA2B

PTN Mini Digital Amplifier



Version: PA2B2013V1.2

NOTICE: Please read this user manual carefully before using this product.

This manual is for operation instruction only, not for any maintenance usage. The functions described in this version are updated till January 2013. Any changes of functions and parameters since then will be informed separately. Please refer to the dealers for the latest details.

This manual is copyright PTN Electronics Limited. All rights reserved. No part of this publication may be copied or reproduced without the prior written consent of PTN Electronics Limited.

All product function is valid till 2013-01-07.

Update History

Version	Date	Update Content
1.0	2012.12.25	First version.
1.1	2012.12.28	Update the pictures related to the IR remote.
1.2	2013.01.07	Modified some operation commands.

Table of Contents

1. Introduction	1
1.1. Introduction to PA2B	1
1.2. Package Contents	1
2. Features	1
3. Specification	2
4. System Connection Introduction	2
4.1. Audio Output	2
4.1.1. Default output: 2x20Watt@4Ohm	2
4.1.2. Bridge connection: 1x40Watt@8Ohm	3
4.1.3. Dual-mono Output	3
4.2. Microphone input	4
4.2.1. 48V phantom power input	4
4.2.2. MIC input	4
4.2.3. LINE input	4
5. Operation of the Control Panel and the IR Remote	5
5.1. Operation of the Control Panel	5
5.1.1. Audio switching	5
5.1.2. Volume/EQ controlling	5
5.2. Usage of the IR Remote	6
6. System Diagram	7
7. Communication Protocol and Command Codes	7
8. Panel Drawing	9
9. Troubleshooting & Maintenance	10
10. Safety Operation Guide	11
11. After-sales Service	12

1. Introduction

1.1. Introduction to PA2B

PA2B is a compact-size digital amplifier (Class-D) with 3 inputs (2 line in and 1 balanced MIC). It is integrated with powerful functions, including bridge connection, dual-mono, EQ control, microphone mixer etc.

It has a good application in different places, including classroom, small meeting room, lecture hall, bar, pub etc.

1.2. Package Contents

- 1 x PA2B (The mounting ears and PA2B are as a whole.)
- 1 x Power Cord
- 1 x User Manual
- 1 x Warranty Card

Notes:

- The IR remote and its battery are offered for charge separately.
- The IR receiver is also offered for charge.
- Please confirm if the product and the accessories are all included, if not, please contact with the dealers.

2. Features

- 2x20Watt@4Ohm as the default amplifier output.
- Bridge connection function. User can switch the PA2B to be 1x40Watt@8Ohm by bridge connection.
- Two stereo audio inputs, switchable by button, IR remote & RS232.
- Volume/Bass/Treble controllable by buttons IR remote & RS232.
- MIC port can support balance/unbalance signal, suppress the external noise effectively.
- Line audio output at 3.5mm jack, with volume controllable.
- Dual-mono function. User can sum up the stereo audio to two times mono audio.
- MIC mixer function. The microphone will be mixed to the line audio output, and be controlled separately.
- MIC input supports 48V phantom power, dynamic MIC and wireless MIC.
- Auto noise gate. It keeps detecting the audio and MIC input, will mute the output when there is no input.
- Ultra low inrush current, no need for power sequencing. This allows multiple PA2B to be powered on simultaneously without overloading power circuits.
- Convection cooler, fan is not needed.
- Antistatic case design: providing good protection for long-term and stable performance.

3. Specification

Audio Input		Audio Output	
Input	2 stereo audio, 1 MIC	Output	1 amplifier, 1 stereo audio
Input Connector	2 RCA 1 3.5mm jack 1 captive screw connector (3P,3.81mm),	Output Connector	1 3.5mm jack 1 captive screw connector (4P, 5.08mm)
Input Impedance	>10KΩ	Output Impedance	50Ω/stereo, 4~8Ω/Amplifier
Audio General			
Frequency Response	20Hz ~ 20KHz	CMRR	>70dB@20Hz~20KHz
SNR	80dB at maximum output	Bandwidth	20Hz ~ 25KHz
Stereo Channel Separation	>75dB@20Hz to 20KHz	THD + Noise	1%@1KHz, 0.3%@20KHz at nominal level
Voltage Gain	32dB	Power Output	2x20 Watts (4 Ohms)
Control Function			
RS232 Control	3-hole phoenix connector	Panel Control	Optional button control
IR Remote	Optional IR remote		
TCP/IP Control	TCP/IP controlled by PTNET(PTN's programmable interface)		

4. System Connection Introduction

4.1. Audio Output

4.1.1. Default output: 2x20Watt@4Ohm

The default output of amplifier is 2x20Watt@4Ohm, so user can connect the amplifier output in the regular way. As the picture below:

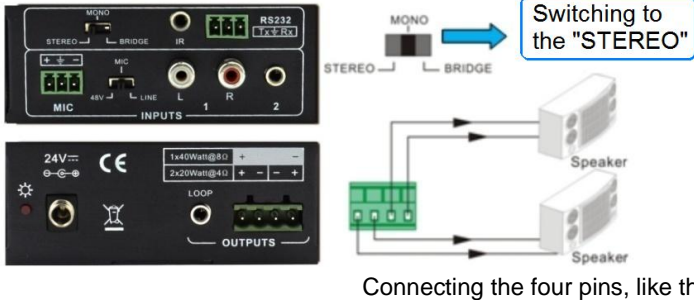

4.1.2. Bridge connection: 1x40Watt@80hm

The PA2B has the bridge connection, to double the output power at 1x40Watt@80hm. It will sum up the input left channel and input right channel to be mono output, and the power is up to 40Watt.

The bridge connection is:

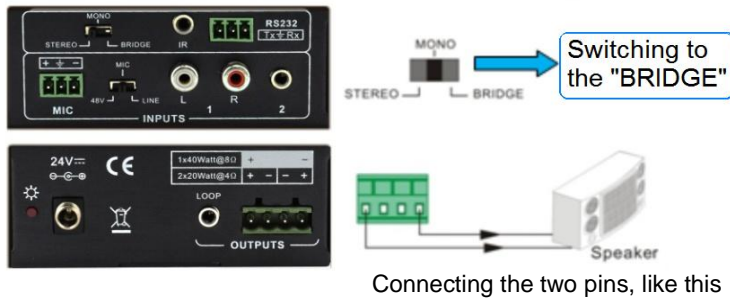

4.1.3. Dual-mono Output

The PA2B also has the function of double-mono output. It can sum up the left and right channel, to be the mono audio output. In this way, the both of the outputs are showing the same mono audio.

The connection is:

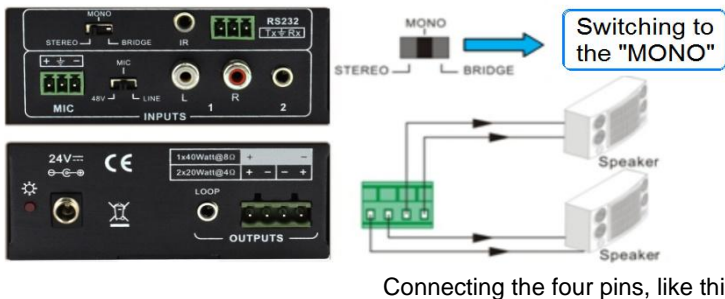

Mini Digital Amplifier

4.2. Microphone input

The microphone input of PA2B has three modes, and different modes use different connections, as the picture below:



4.2.1. 48V phantom power input

When the switch turns to “48V”, the MIC input will provide a 48V phantom power. This is usually used for power supply for condenser microphone, Connection is:

“+” connects to positive, “-” connects to negative and “ \perp ” to ground.

Note: In this mode, only condenser microphone can be connected with.

4.2.2. MIC input

When the switch turns to “MIC”, the microphone input is used for connecting with dynamic microphone. There are two different connections:

1) Unbalanced connection:

“ \perp ” connects to ground, and “-” connects to signal.

“ \perp ” connects to ground, and “+” connects to signal.

2) Balanced connection: “+” connects to positive, “-” connects to negative and “ \perp ” connects to ground.

4.2.3. LINE input

When the switch turns to “LINE”, the microphone input is used for connecting with normal audio or wireless microphone output. There are two different connections:

1) Unbalanced connection:

“ \perp ” connects to ground, and “-” connects to signal.

“ \perp ” connects to ground, and “+” connects to signal.

2) Balanced connection: “+” connects to positive, “-” connects to negative and “ \perp ” connects to ground.

5. Operation of the Control Panel and the IR Remote

5.1. Operation of the Control Panel

The buttons provides the control of volume/EQ control and switching. The following content introduces audio switching and EQ control in detail.

5.1.1. Audio switching

There are two switchable stereo audio inputs, one 2xRCA input, and one 3.5mm jack input, switchable through the buttons as below:

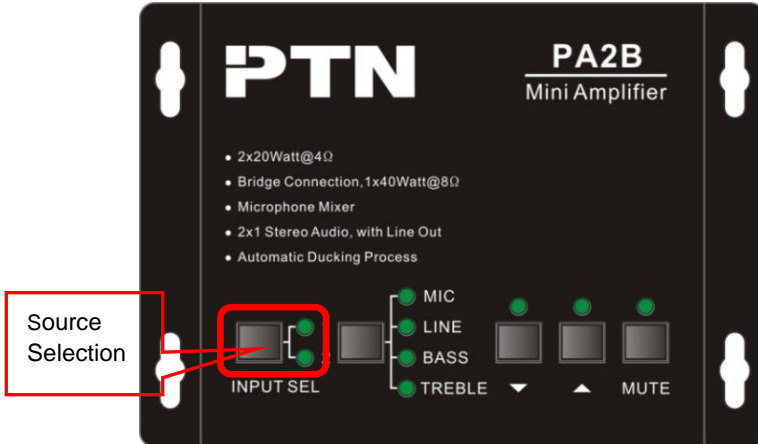

5.1.2. Volume/EQ controlling

The line volume and MIC volume can be controlled by the buttons.

The MIC Volume/LINE volume/LINE bass/LINE treble will be selected by the buttons, and controlled up/down/mute by the function buttons. Please check the picture below:

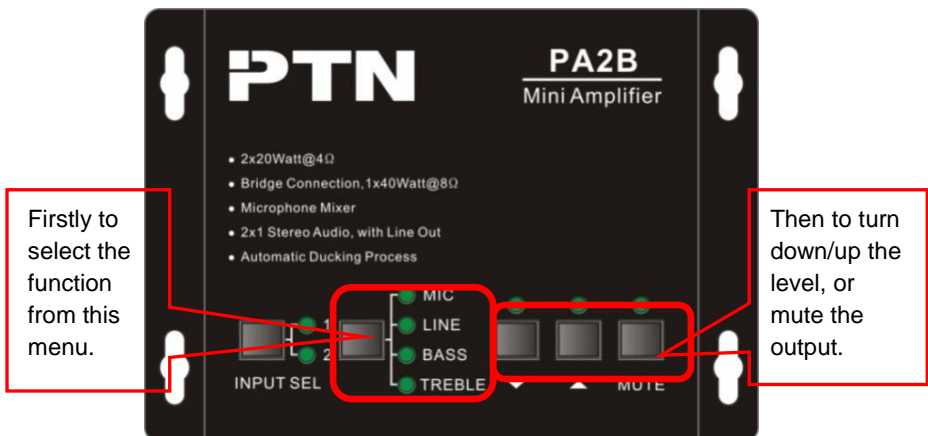

Mini Digital Amplifier

For example, to turn up the line volume, you should select the “LINE” first, and then press the button “▲”.

5.2. Usage of the IR Remote

Audio Inputs
 2 RCA dual-mono audio inputs
 1 3.5mm jack

Audio Controlling Modes
MIC: turn up/down the microphone volume.
LINE: turn up/down the line volume.
BASS: bass tuning
TREBLE: treble of line volume.

Mute Mode:
MIC: Mute the microphone volume.
LINE: Mute the line volume.
SPEAKER: Unmute

IR receiver head, works in conjunction with the IR remote. Please point the IR remote at the IR receiver when use, to avoid getting out of control as there is no signal detected.

3.5mm jack
 Insert it into the specialized PA3 socket (3.5mm), to connect the IR receiver with PA3.

Notice: The IR remote, the IR receiver, and the battery of the IR remote are all offered for charge.

6. System Diagram

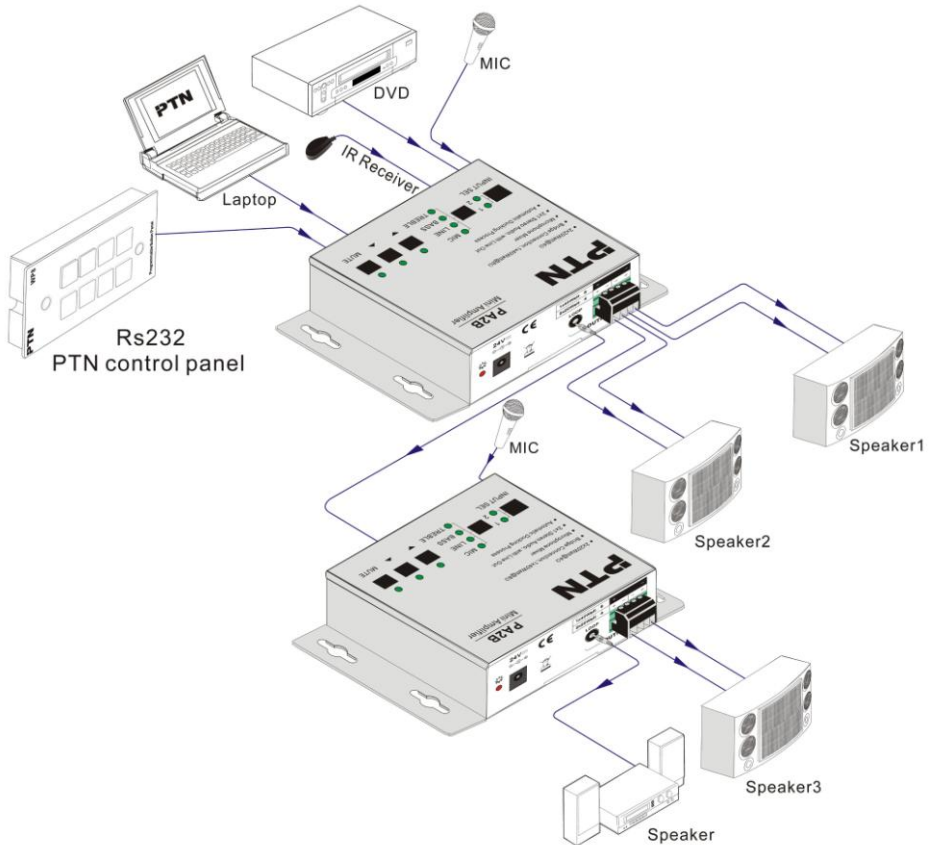

7. Communication Protocol and Command Codes

Communication Protocol: RS232 Communication Protocol

Baud rate: 9600 Data bit: 8 Stop bit: 1 Parity bit: none

Command	Function Description	Feedback Code
1A1.	Switching the audio to input 1	A: 1 -> 1
2A1.	Switching the audio to input 2	A: 2 -> 1
0A0.	Mute Audio of MIC and Line out	Mute Audio
1A0.	Mute audio of MIC	Mute MIC
2A0.	Mute audio of line out	Mute LIN
0A1.	Unmute Audio	Unmute Audio
600%	Checking the working status	A: 1 -> 1 Volume: 30

		Bass: 00 Treble: 00
601%	MIC volume up	Volume of MIC: 51
602%	MIC volume down	Volume of MIC: 51
603%	Line volume up	Volume of LINE: 51
604%	Line volume down	Volume of LINE: 51
605%	Bass level up	Bass of LINE: 04
606%	Bass level down	Bass of LINE: 04
607%	Treble level up	Treble of LINE: 04
608%	Treble level down	Treble of LINE: 04
609%	Initialization, back to the default setting	A: 1 -> 1 Volume: 50 Bass: 04 Treble: 04
5[x][x]%	Preset MIC volume, [xx] arranges from [00] to [60]. 61 degrees in total.	Volume of MIC: 50
7[x][x]%	Preset line volume, [xx] arranges from [00] to [60]. 61 degrees in total.	Volume of LINE: 50
8[x][x]%	Preset the bass level, [xx] arranges from [00] to [08]. 9 degrees in total.	Bass of LINE: 04
9[x][x]%	Preset the treble level, [xx] arranges from [00] to [08]. 9 degrees in total.	Treble of LINE: 04

Notice:

- 1: The letter inside bracket [] is the variable code, which is changeable.
- 2: The bracket [] is not included to the RS232 commands.
- 3: Any dot "." after the letters is part of the commands.

Example 1:

Switching the input 2 to the line out, RS232 command is: **[2A1.]**

Example 2:

Turning up the volume of line audio, RS232 command is: **[603%]**

Example 3:

Preset the MIC volume to "21" degree, RS232 command is: **[521%]**

Example 4:

Checking the working status of PA2B, RS232 command is: **[600%]**

8. Panel Drawing

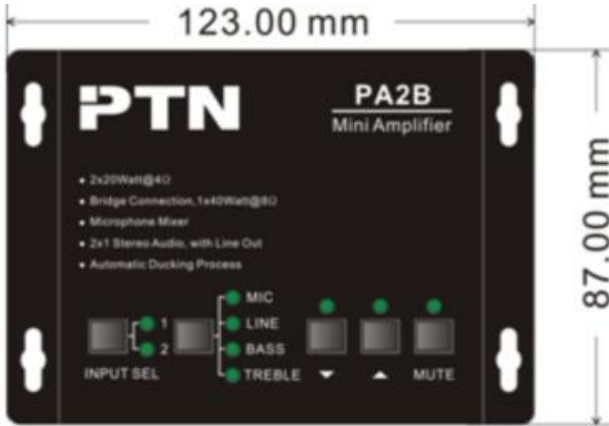

9. Troubleshooting & Maintenance

1) When there is no output audio:

- Check if there is any signal at the input.
- Check if there is any signal at the output.

We can check these by using an oscilloscope or a multimeter. If there is no signal input/output, maybe the input/output cables broken or the connectors loosen, please change for another cable.

- Check if the output port number is the same with the controlled one.
 - If not the problem mentioned above, probably there is something broken inside the unit, please send it to the dealer for repairing.
- 2) If the **POWER** indicator doesn't work or no respond to any operation, please make sure the power cord connection is good.
- 3) If the output sound is interfered, please make sure the system is grounded well.
- 4) If the static becomes stronger when connecting the audio connectors, it probably due to bad grounding, please check the grounding and make sure it connected well, otherwise it would damage the converter.
- 5) If the PA2B amplifier cannot be controlled by the keys on the front panel, RS232 port or IR remote, the unit may has already been broken. Please send it to the dealer for repairing.

10. Safety Operation Guide

In order to guarantee the reliable operation of the equipments and safety of the staff, please abide by the following proceeding in installation, using and maintenance:

- 1) The system must be earthed properly. Please do not use two blades plugs and ensure the alternating power supply ranged from 100v to 240v and from 50Hz to 60Hz.
- 2) Do not put the switcher in a place of too hot or too cold.
- 3) As the power generating heat when running, the working environment should be maintained fine ventilation, in case of damage caused by overheat.
- 4) Please cut off the general power switch in humid weather or left unused for long time.
- 5) Before following operation, ensure that the alternating current wire is pull out of the power supply:
 - Take off or reship any components of the equipment.
 - Take off or rejoin any pin or other link of the equipment.
- 6) As to non-professional or without permission, please DO NOT try to open the casing of the equipment, DO NOT repair it on your own, in case of accident or increasing the damage of the equipment.
- 7) DO NOT splash any chemistry substance or liquid in the equipment or around.

11. After-sales Service

- 1) If there appear some problems when running PA2B, please check and deal with the problems reference to this user manual. Any transport costs are borne by the users during the warranty.
- 2) You can email to our after-sales department or make a call, please tell us the following information about your cases.
 - Product version and name.
 - Detailed failure situations.
 - The formation of the cases.
- 3) We offer products for all three-year warranty, which starts from the first day you buy this product (The purchase invoice shall prevail).
- 4) Any problem is same with one of the following cases listed, we will not offer warranty service but offer for charge.
 - Beyond the warranty.
 - Damage due to incorrectly usage, keeping or repairing.
 - Damage due to device assembly operations by the maintenance company non-assigned.
 - No certificate or invoice as the proof of warranty.
 - The product model showed on the warranty card does not match with the model of the product for repairing or had been altered.
 - Damage caused by force majeure.

Remarks: For any questions or problems, please try to get help from your local distributor, or email PTN at: support@PTN-electronics.com.